

**NEW**

# 114-600A - 114-800A



## AUTOMATIC BOLLARD WITH ELECTROMECHANICAL ACTUATOR

New automatic bollards **easy-to-install and use**, the ideal solution for **residential projects**, specifically for the management of private parkings and driveways.

Despite being an entry level product, it is made of AISI 304 stainless steel and designed for installations of medium frequency of use, **approx. 100 cycles/day**.

### MAIN FEATURES

- **Reduced installation time** (less than an hour) as it is supplied preassembled with bollard in its foundation box ready to install.
- **Simplified fitting** using a manual auger drill\*.
- **Control unit** designed for systems of max. 3 bollards.
- **Easy transport** as the bollard and its components are shipped in a unique box.
- **Compatible** with all Pilomat control systems (transmitters, key selector,...).

Electromechanical bollards are the products with the **best quality - price ratio** in the Pilomat range and help **reducing the environmental risk**.

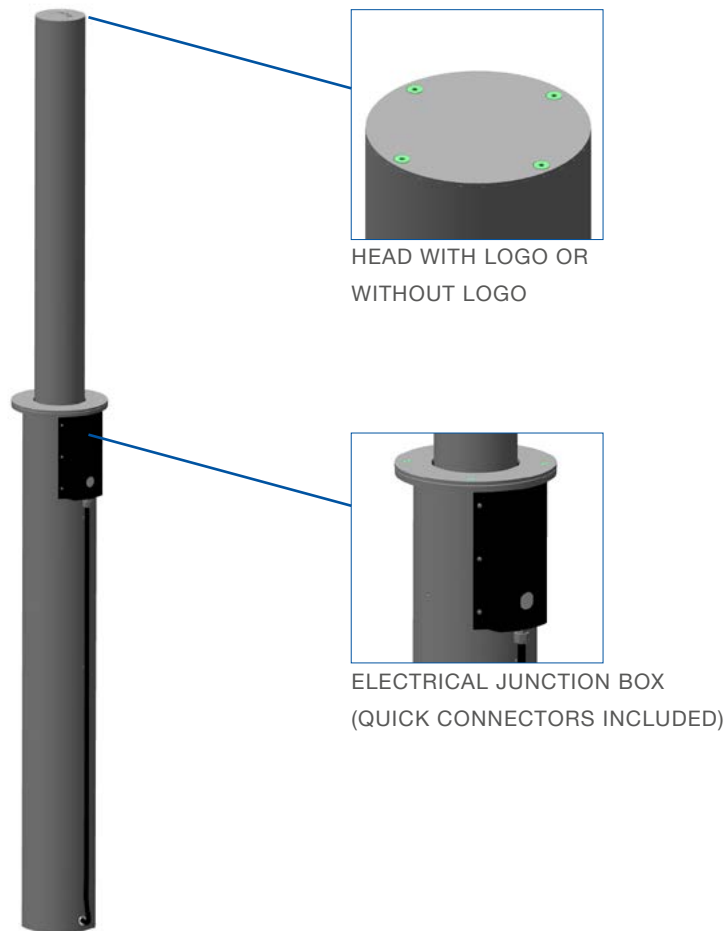

**PILOMAT**  
**HÖRMANN**  
100% MADE IN ITALY

PAG.1/3

PILOMAT s.r.l.  
www.pilomat.com / pilomat@pilomat.com  
Via Zanica 17/p, 24050, Grassobbio (BG) Italy  
Tel. +39.035.29.72.20  
Copyright 2024© Pilomat S.r.l. All rights reserved

REVIEW 14/02/2024

## AVAILABLE ITEMS

BOLLARD 114-600 COMPLETE WITH FOUNDATION BOX – STAINLESS STEEL BRUSHED AISI 304

BOLLARD 114-800 COMPLETE WITH FOUNDATION BOX – STAINLESS STEEL BRUSHED AISI 304

MANAGEMENT BOARD (TO BE FITTED)

MANAGEMENT BOARD ALREADY FITTED (IN HOUSING)

REMOTE RADIO RECEIVER

RADIO TRANSMITTER TWO CHANNEL

INDUCTIVE DETECTOR FOR TWO INDUCTIVE LOOPS

INDUCTIVE LOOPS

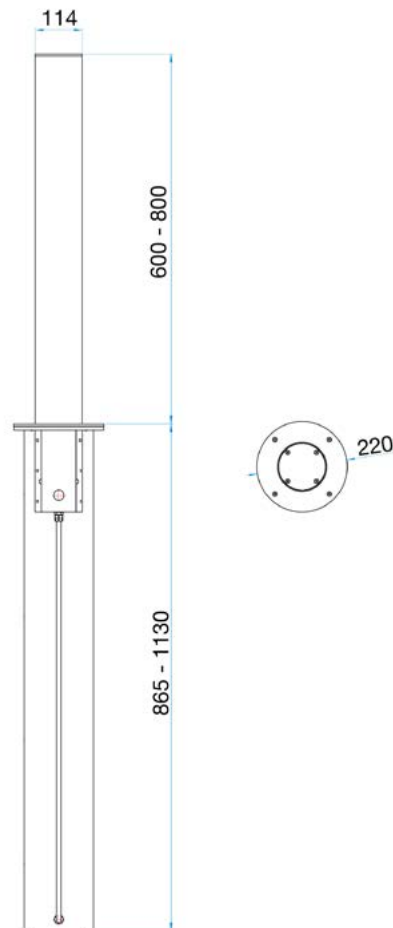

# 114-600A - 114-800A



	114-600A	114-800A
CYLINDER MATERIAL	X5CrNi 18-10 (AISI 304) STAINLESS STEEL BRUSHED	
CYLINDER DIAMETER	114mm	
CYLINDER HEIGHT	600mm	800mm
CYLINDER THICKNESS	3mm	
MOVEMENT PRINCIPLE	BUILT-IN ELETTROMECHANICAL ACTUATOR	
RISING TIME	6,5 s	10 s
LOWERING TIME	6,5 s	10 s
VOLTAGE FOR MOTOR	24V (max. 3A)	
CONNECTION TO CONTROL UNIT	QUICK CONNECTOR (CABLE NOT INCLUDED)	
TYPE OF USE	100 CYCLES/DAY	
LIFE UNITS	500.000 CYCLES	
NOMINAL OPERATING TEMPERATURE	-40°C +70°C (FOR LOW TEMPERATURES SEE HEATING RESISTANCE)	
PACKAGING DIMENSION	120 x 22 x 22 cm	150 x 22 x 22 cm

