

275/P10 600A-800A



HYDRAULIC BOLLARD WITH BUILT-IN UNIT

The 275/P10 600A and 275/P10 800A are two variants of P SERIES, which has the same general features, but the cylinder is thicker in order to increase the resistance of breakage. They are typically used in business and industry, combined with the classical gates in order to improve the level of passive safety, preventing theft of vehicles and its cargo inside the area.

The 275/P10 bollards are available with a large number of optional accessories that allow you to customize your system according to your security needs.



PAG.1/3

PILOMAT
HÖRMANN
100% MADE IN ITALY

PILOMAT s.r.l.
www.pilomat.com / pilomat@pilomat.com
Via Zanica 17/p, 24050, Grassobbio (BG) Italy
Tel. +39.035.29.72.20
Copyright 2021© Pilomat S.r.l. All rights reserved

REVIEW 09/09/2021

*Information in this document is for reference only. In pursuit of its policy of continuous refinement and improvement, Pilomat reserves the right to amend this information at any time and without prior notice.
Picture shown is for illustration purpose only.*

AVAILABLE ITEMS

BOLLARD 275/P10 FEV - NORMAL STEEL PAINTED

BOLLARD 275/P10 IXV - STAINLESS STEEL PAINTED

BOLLARD 275/P10 IXS - STAINLESS STEEL BRUSHED

FOUNDATION BOX IN ALUZINC FOR 275/P10 - COUNTERFRAME AND BRACKETS
ONE FOUNDATION BOX FOR EACH BOLLARD

CONTROL UNIT FOR 275/P10

MULTILED LIGHTING STRIP- 25 LED POINTS

ACOUSTIC WARNING SIGNAL FOR AUTOMATIC BOLLARD

REFLECTING ADHESIVE STRIP - WHITE (NO-LOGO)

HEAD WITHOUT LOGO FOR 275/P10

PAINTING WITH RAL COLOUR ON REQUEST

BIODEGRADABLE OIL FOR HYDRAULIC UNIT

HEATING RESISTANCE FOR BOLLARDS - TRANSFORMER AND THERMOSTAT
ONE RESISTANCE FOR EACH BOLLARD

RADIO RECEIVER

RADIO TRANSMITTER TWO-CHANNEL

TRAFFIC LIGHT WITH TWO LIGHTS (GREEN-RED)

INDUCTIVE DETECTOR FOR LOOPS

INDUCTIVE LOOPS

TIMER PROGRAMMER

INDUCTIVE CARD READER

LOCK SELECTOR

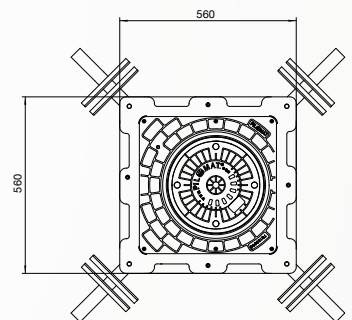
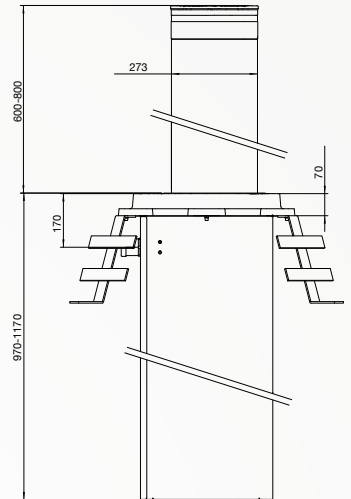

275/P10 600A-800A



	275/P10-600A	275/P10-800A
CYLINDER MATERIAL	S235JR NORMAL STEEL - X5CrNi 18-10 (AISI 304) STAINLESS STEEL X5CrNiMo 17-12-2 STAINLESS STEEL	
CYLINDER DIAMETER	273mm	
CYLINDER HEIGHT	600mm	
CYLINDER THICKNESS	10mm	
MOVEMENT PRINCIPLE	HYDRAULIC	
CYLINDER NORMAL STEEL FINISH	ANTI-CORROSION TREATMENT - GREY ANTHRACITE STANDARD PAINTING	
CYLINDER STAINLESS STEEL FINISH	GREY ANTHRACITE STANDARD PAINTING OR BRUSHING	
REFLECTING ADHESIVE STRIP	STANDARD - HEIGHT 55mm	
RISING SPEED	15cm/s	13cm/s
	(OPTIONAL: E.F.O. RISING TIME 1,5s)	
LOWERING SPEED	30cm/s	32cm/s
MANUAL EMERGENCY LOWERING	STANDARD	
SAFETY REVERSAL	STANDARD	
CONNECTION LINE TO CONTROL UNIT	STANDARD 10m (MAX. LENGTH 80m - WITH HEATING RESISTANCE MAX. 50m)	
VOLTAGE FOR CONTROL UNIT	230/400VAC (+/- 10%) 50/60HZ	
HYDRAULIC UNIT	BUILT-IN THE BOLLARD	
PROTECTION CLASS	IP67	
TYPE OF USE	INTENSIVE - 2.000 CYCLES/DAY	
LIFE UNITS	3.000.000 CYCLES	
IMPACT RESISTANCE (WITHOUT DEFORMATION)	40.000 J CERTIFIED TUV RHEINLAND	
BREAKOUT RESISTANCE	400.000 J	
NOMINAL OPERATING TEMPERATURE	-40 °C +70 °C (FOR LOW TEMPERATURES SEE THE HEATING RESISTANCE)	
LOAD CLASS (EN124)	D400	

